

# UMB AC07

## Industrial Modular UPS

from 20 to 120 kW

AC UPS

Borri Modular AC Uninterruptible Power System UMB AC07 is designed and developed to withstand harsh industrial environment and operating conditions of industrial applications with state-of-the-art technology, providing reliable and customized system solutions. The modular design ensures a very high reliability and a very low mean time to repair (MTTR) making the Borri UMB AC07 UPS system with the highest possible availability.

The Borri Modular UPS provides scalability and very high operating efficiency, even at partial loads, the real running costs are minimized without the need to compromise on power quality. Each UMB AC07 modular UPS module is a highly efficient double conversion, serial on-line UPS (VFI-SS-111).

With decades of experience in industrial power solutions, Borri offers complete AC modular UPS systems with highly reliable, robust quality and flexible, longest design life.



## Industrial Power

### Applications

- Power Generation.
- Power Utility.
- Oil & Gas.
- Transportation.
- Water Desalination.
- Marine.
- Chemical Industries.
- Other Heavy Industries.

### Main features

- No single point of failure.
- UPS power range up to 120 kW.
- High efficiency in double conversion up to 96%.
- Increased power (kVA=kW).
- Single and N+1 configurations.
- High power density.
- Low Current Harmonics (THDi).

# UMB AC07

## Industrial Modular UPS

### UMB AC07 technical data

Ratings (kW)	20	40	60	80	100	120
Module nominal power (kW)	20 (3x6.7 kW)					
<b>Input</b>						
Input voltage	380 / 400 / 415 Vac 3-phase with neutral					
Input frequency	45-65 Hz (auto-sensing or selectable by the User)					
Input voltage range	400 V +15%/-20%					
Power factor	0,99					
Input THDi	<3%					
Bypass input voltage	380 / 400 / 415 Vac 3-phase ±20%					
<b>Battery</b>						
Nominal voltage	216 V to 252 V					
Battery technologies	Maintenance-free Lead Acid (VRLA - AGM)					
Charging Current (A)	7.5	15	22.5	30	37.5	45
<b>Output</b>						
Nominal voltage	380 / 400 / 415 Vac 3-phase + N +/- 1%; 220 / 230 / 240 Vac 1-phase +/- 1% (only 20 kW)					
Frequency	50/60 Hz					
Voltage regulation	±1% static; dynamic: IEC/EN 62040-3 Class 1					
Overload capacity	115% for 10 min; 135% for 60 sec					
Harmonic Distortion THDv	<1% linear load; <5% non-linear load					
<b>System</b>						
Dimensions WxDxH (mm)	600x800x2100			1200x800x2100		
Cooling	Forced ventilation					
Colour	RAL 7035 (others on option)					
Protection degree (IEC 60529)	IP 20 (optional up to IP 42)					
Efficiency (AC/AC)	Up to 96%					
<b>Environmental</b>						
Operating temperature	0°C to +40°C (derated up to 55°C)/ Storage: 10°C to +70°C					
Altitude	< 1000 m without power reduction, > 1000 m with reduction of 0.5% per 100 m					
Audible noise at 1 meter (dBA)	50 to 65 (depending on power rating)					
<b>User Interface</b>						
Front panel	Cabinet graphic display, mimic LED panel and keyboard, local EPO					
Connectivity	Included: RS232 card, USB. Optional: Modbus-RTU, PROFIBUS DP, MODBUS TCIP					
<b>Standards</b>						
Quality assurance, environment, health and safety: ISO 9001:2008, ISO 14001:2004, BS OHSAS 18001:2007; Safety: IEC EN 62040-1; EMC: IEC EN 62040-2; Environmental aspects: IEC EN 62040-4; Test and performance: IEC EN 62040-3 VFI-SS-111; Protection degree: IEC 60529; Marking: CE						

## Standard features

- Proven microprocessor control.
- Large LCD and LED display with mimic panel and history.
- Wide selection of alarms, indications and measurements.
- Communication ports and potential free contacts.
- Operates with Lead acid batteries (VRLA - AGM).
- Other AC input voltages.
- RS-232 / RS-485.

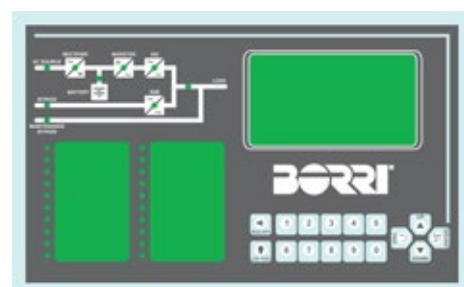

## UMB AC07 schematic

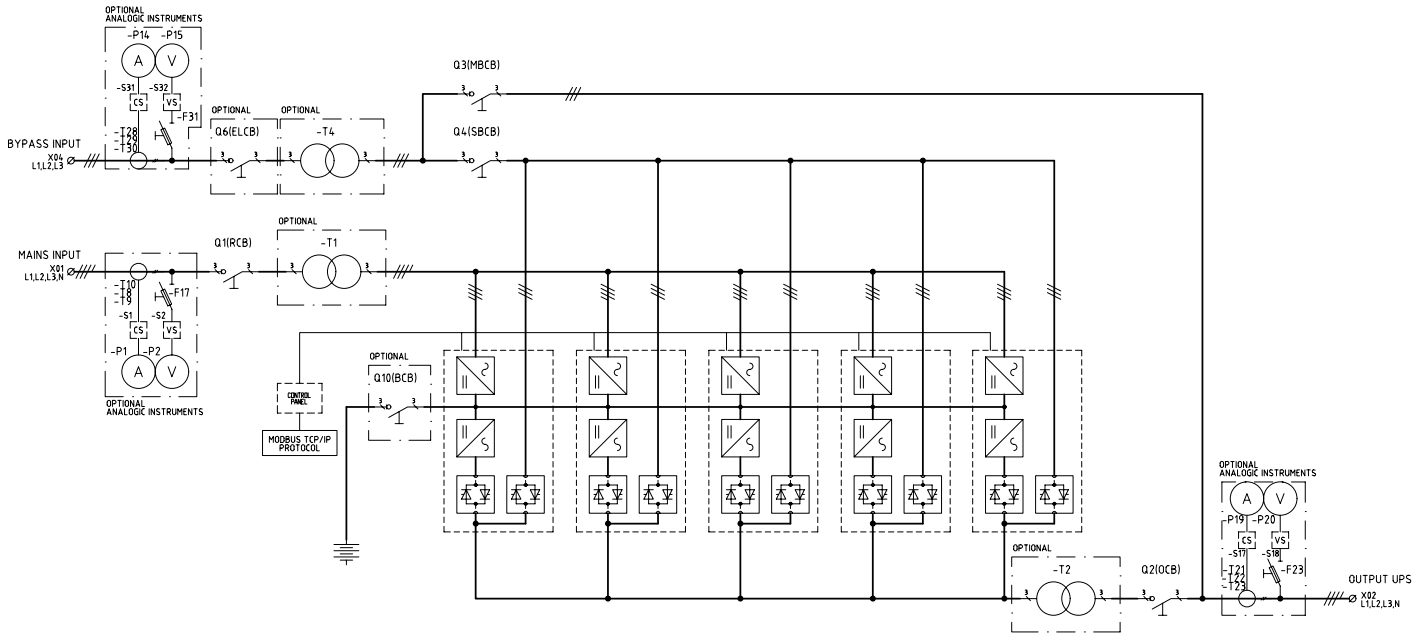

## Options

Borri's engineer can help you to design the best solution for your application with a wide range of options, some of which are:

### System

- N+1 system configuration.
- Hot swap capability.
- Special mains input voltages up to 690 VAC.
- Input/Output/Bypass isolation transformer.
- Additional battery charger.
- Battery CB or fuse box.
- Bypass voltage stabiliser.
- AC distribution.
- Battery cabinet.

### Alarms and measurement

- Analogue meters.
- Battery circuit failure alarm.
- Ground fault alarm.

### Control options

- Communication:
  - TCP / IP interface
  - Protocol converters Profibus DP
  - J-bus DNP3
  - IEC 61850

### Mechanical

- Protection up to IP 42.
- Vermin proof.
- Top cable entry.
- AC 1-phase socket.
- Cabinet heater.
- Special colour.
- Protection plates.
- Special cable marking (both ends).
- Air filters at air inlet.



## Batteries

Borri has over 80 years of experience in designing and supplying AC and DC UPS systems with batteries.

With our vast experience in battery technologies and our close technical and commercial relationships with the world largest manufacturers of Nickel Cadmium, Lead Acid and Lithium ion Industrial batteries we are able to offer expert advice on the specifying, selection, operation and testing of batteries to best suite your application and needs.

## Service

Customer's expectation defines Borri's priority from the early analysis of the project requirements to a worldwide commissioning and service.

Many thousands of systems have been successfully installed and maintained globally; with continuous support from a highly trained team of expert, certified technicians and engineers.

From the professional set-up of Borri's training centre or on site, the training and service team provide support and tailored training at Borri or at your site. You can be assured of Borri support to the highest standards no matter where in the world you are.

- Planning, installation, commissioning.
- Maintenance and Service.
- Analytical testing.
- Battery tests.
- Spare parts.
- Training.

## Who we are

Borri has been developing and building uninterruptible power systems since 1932 and is a global provider of power electronics systems and solutions for harsh industrial and demanding critical power requirements.

Borri is a brand of Legrand, a publicly traded company and a global specialist in electrical and digital infrastructures, offering high-value -added products and solutions for commercial, residential and industrial buildings.

Borri's R&D vast expertise in all facets of firmware, power electronics and mechanical design provides innovative solutions for tomorrows problems in Industrial and Critical Power applications.

The company prides itself on its first-class service and superior engineering disciplines. To ensure sustained quality, Borri manages all its processes in house from feed studies to design, production and after sales service technology.

Based in Bibbiena, Italy with over 15,000 m<sup>2</sup> production area, Borri operates across all five continents with subsidiaries in USA, Canada, Germany, UAE, India and Malaysia.

It has also established a strong distributor network, able to deliver on site support and technical guidance indicative of our own capabilities.



**Since 1932, securing your power with passion and commitment.**

