

CertaUPS

C650/C650R USER MANUAL
A COMPLETE INSTALLATION
AND USER GUIDE

THE C650 SERIES

An uninterruptible power supply (UPS) incorporating online double conversion technology, which eliminates all mains power disturbances and IOT software

www.certaups.com

For assistance, please contact your local CertaUPS partner.

Scan to download the APP



Table of Contents

SAFETY INSTRUCTIONS.....	6
PRODUCT SAFETY	7
SPECIAL PRECAUTIONS.....	7
1. INTRODUCTION	8
1.1 Product Features.....	8
1.2 Environmental Protection	8
2. PRODUCT OVERVIEW	9
2.1 MODEL LIST.....	9
2.2 PRESENTATION	10
2.2.1 C650 Tower Model:.....	10
2.2.2 C650R Rack model:.....	12
3. INSTALLATION	13
3.2 CHECKING THE ACCESSORY KIT	14
3.3 MECHANICAL INSTALLATION.....	15
3.3.1 Tower model.....	15
3.3.2 Rack model.....	15
3.4 Power cables connection	18
3.4.1 Input /Output wiring specifications.....	18
3.4.2 Wiring for AC Cable (AC source to UPS)	18
3.4.3 Wiring with external battery module (C650 / C650R EBM) (DC source to UPS)	19
3.4.4 Wiring with RT MBP (MBP source to R/T UPS only)	20
4. PARALLEL SYSTEM INSTALLATION AND OPERATION (OPTIONAL)	21
4.1 WIRING FOR AC CABLE	21
4.2 WIRING FOR PARALLEL SIGNAL CABLE	22
4.3 PARALLEL SYSTEM OPERATION.....	22
5. OPERATION.....	23
5.1 LCD PANEL	23
5.2 LCD DESCRIPTION	24
5.3 DISPLAY FUNCTIONS.....	25
5.4 USER SETTINGS.....	26
5.5 STARTING THE UPS WITH UTILITY.....	27
5.6 STARTING THE UPS ON BATTERY	27
5.7 UPS SHUTDOWN	27







6.	COMMUNICATION.....	28
6.1	RS232 AND USB	28
6.2	UPS REMOTE CONTROL FUNCTIONS	28
6.3	IOT	29
6.4	Modbus TCP.....	29
6.5	Intelligent Card (optional)	29
6.6	SOFTWARE.....	30
6.6.1	Winpower	30
6.6.2	WinPower View APP	31
7.	UPS MAINTENANCE	32
	UPS CARE	32
7.1	TRANSPORTING THE UPS.....	32
7.2	STORING THE UPS	32
7.3	BATTERY REPLACEMENT	33
7.4	REPLACING THE EBM	33
7.5	RECYCLING A UPS	34
8.	TROUBLESHOOTING	35
8.1	ALARMS & FAULTS.....	35
8.2	SILENCING THE ALARM	37
9.	TECHNICAL DATA	37
9.1	BLOCK DIAGRAM	37
9.2	UPS SPECIFICATION	37

SAFETY INSTRUCTIONS

SAVE THESE INSTRUCTIONS

This manual contains important instructions that should be followed during installation and maintenance of the UPS and batteries.

The UPS covered in this manual are intended for installation in an environment within 0° - 50°C (excluding batteries) and free from conductive contaminants.

SYMBOL	DEFINITION
	Important instructions that must always be followed
	Caution, risk of electric shock – observe the warning associated with the risk of electric shock symbol
	EU separate collection and lead content mark for lead acid batteries. Indicates that the battery must not be disposed of as normal household waste and instead be separately collected and recycled.
	EU separate collection mark for waste electrical and electronic equipment (WEEE). Indicates that the item must not be disposed of as normal household waste and instead be separately collected and recycled.
	Information, advice, help
	Refer to the user manual

SAFETY OF PERSONS

- **RISK OF VOLTAGE BACK FEED.** The system has its own power source (the battery). Isolate the UPS and check for hazardous voltage upstream and downstream during lockout-tagout operation. Terminal blocks may be energised even if the system is disconnected from the AC power source.
- Dangerous voltage levels are present within the system. It should be opened exclusively by qualified service personnel.
- The system must be properly grounded.
- The battery supplied with the system contains small amounts of toxic materials. To avoid accidents, the directives listed below must be observed:
 - Servicing of batteries should be performed by personnel knowledgeable about batteries and the required precautions.
 - When replacing batteries, replace with the same type and number of batteries or battery packs.
 - Do not dispose of batteries in a fire. The batteries may explode.
 - Batteries constitute a danger (electrical shock, burns). The short-circuit current may be very high.
- Precautions must be taken for all handling:
 - Wear rubber gloves and boots.
 - Do not lay tools or metal parts on top of batteries.
 - Disconnect the charging source before connecting or disconnecting battery terminals.
 - Determine if battery is inadvertently grounded. If inadvertently grounded, remove source from ground. Contact with any part of a grounded battery can result in electrical shock. The likelihood of such shock can be reduced if such grounds are removed during installation and maintenance (applicable to equipment and remote battery supplies not having a grounded supply circuit).

PRODUCT SAFETY

- The UPS connection instructions and operation described in the manual must be followed in the indicated order.
- UPS enclosure IP rating IP20.
- CAUTION - To reduce the risk of fire, the unit should only be connected to a circuit provided with branch circuit overcurrent protection.
- The upstream circuit breaker for Normal AC/Bypass AC must be easily accessible. The unit can then be disconnected from the AC power source by opening this circuit breaker.
- An additional AC contactor is used for back feed protection and must comply with IEC/EN 62040-1
- Disconnection and overcurrent protection devices shall be provided by others for permanently connected AC input (Normal AC/Bypass AC) and AC output circuits.
- Check that the indications on the rating plate correspond to your AC powered system and to the actual electrical consumption of all the equipment to be connected to the system.
- For PLUGGABLE EQUIPMENT, the socket-outlet shall be installed near the equipment and shall be easily accessible.
- Never install the system near liquids or in an excessively damp environment.
- Never let a foreign body penetrate inside the system.
- Never block the ventilation grates of the system.
- Never expose the system to direct sunlight or source of heat.
- If the system must be stored before installation, storage must be in a dry place.
- The admissible storage temperature range is -25°C to +55°C without battery (-15°C to +40°C with battery).
- TN-S/IT/TN-C/TT of the electrical supply system may be connected by UPS.
- This UPS may be provided with a maximum of 6 extension battery cabinets or equivalent.

SPECIAL PRECAUTIONS

- The UPS and EBMs are heavy: wear safety shoes and use vacuum lifters preferentially for handling operations.
- All handling operations will require at least two people (unpacking, lifting, installation in rack system).
- Before and after the installation, if the UPS remains de-energized for a long period, the UPS must be energized for a period of 24 hours, at least once every 6 months (for a normal storage temperature of less than 25°C). This charges the battery, thus avoiding possible irreversible damage.
- During the replacement of a Battery Module, it is imperative to use the same type and number of batteries as the original Battery Module provided with the UPS to maintain an identical level of performance and safety.
- This is a category C3 UPS product. In a residential environment, this product may cause radio interference, in which case the user may be required to take additional measures.

1. INTRODUCTION

Thank you for selecting our UPS to protect your electrical equipment.

We recommend that you take the time to read this manual to take full advantage of the many features of your UPS. Before installing your UPS, please read the safety instructions. Then follow the indications in this manual.

1.1 Product Features

The UPS protects your sensitive electronic equipment from the most common power problems, including power failures, power sags, power surges, brownouts, line noise, high voltage spikes, frequency variations, switching transients, and harmonic distortion.

Special characteristics:

- Double converter with pure sine waveform output
- Full digital control
- Output power factor = 1
- High charger capability, the charger current is up to 12Amps
- Smart charging method to expand battery lifetime
- EBM quantity auto-detection
- Communication ports: RPO, Dry in, Dry out, intelligent slot, USB, RS232
- IoT: Ethernet(default) and Wireless (optional)
- Dot-matrix LCD, supports multi-language
- ECO Mode
- Start-able without battery

1.2 Environmental Protection

Products are developed according to an eco-design approach.

Substances

This product does not contain CFCs, HCFCs or Asbestos

Packing

To improve waste treatment and facilitate recycling, separate the various packing components

- The cardboard we use comprises over 50% of recycled cardboard.
- Sacks and bags are made of polyethylene.
- Packing materials are recyclable.
- Follow all local regulations for the disposal of packing materials.

Product

The product is mainly made up of recyclable materials.

Dismantling and disassembly must take place in compliance with all local regulations concerning waste. At the end of its service life, the product must be transported to recycling centres, re-use and treatment facilities for Waste Electrical and Electronic Equipment (WEEE).

Battery

This product contains lead-acid batteries that must be processed according to applicable local regulations concerning batteries.

The battery may be removed to comply with regulations and given correct disposal.

2. PRODUCT OVERVIEW

2.1 MODEL LIST

1. 'B' model means 'standard model' with batteries, 'C' model means 'long backup time model' without batteries.
2. 16 or 20 batteries could be selected for the UPS and EBM (external Battery Module)
3. The weight in this table is for reference only, please see the labels on the carton for details.
4. Dimension 'D' is chassis only, not including the panel.

TOWER MODEL

PRODUCT	NET WEIGHTS (kg)	UNIT SIZE (WxDxH) (mm)
C650-060-C	13.5	225x416x354
C650-100-C	15.5	
C650-060-B	57.9	225x416x589
C650-100-B	68.2	
EBM	124	

RACK MODEL

PRODUCT	NET WEIGHTS (kg)	UNIT SIZE (WxDxH) (mm)
C650R-060-C	13.6	438x540x88(2U)
C650R-100-C	15.5	
C650R-060-B	13.3	
C650R-100-B	15.2	
EBM 240 9AH	60.5	438x559x129(3U)
EBM 240 7AH	56.1	

Optional modules and accessories:

If you wish to order other types of function modular or accessories, please contact distributors/partners.

Type	Description	Remark
R MBP	R 6K/10K MBP	For RT 1-1 model only
Intelligent Card	Dry Contact card (C-Relay)	See in chapter 6.5
	NMC card (C-NMC)	
	MODBUS card (C-Modbus)	
EMP	Temperature and humidity sensors	
WLAN module	WLAN module (C-WIFI)	Wireless connection for IoT
COMM Cable	RS232 CABLE	For RS232 communication
Parallel Kit	For parallel system installing	See in chapter 4.0
Battery cable	Battery cable (16 batt.)	1.8m length,

	for UPS connect with user's own EBM	see in chapter 3.4.3
	Battery cable (20 batt.) for UPS connect with user's own EBM	
Rail kit	Rail kit for R model in Rack installing	See in chapter 3.3.2
Gland kit	Gland kit for R model	For R UPS/MBP model
	Gland kit for Tower model	For Tower UPS model

2.2 PRESENTATION

2.2.1 C650 Tower Model:

UPS Module

Front view

1. ventilation area
2. LCD module, including
 - 2(1) button
 - 2(2) LCD screen
 - 2(3) LED indicator

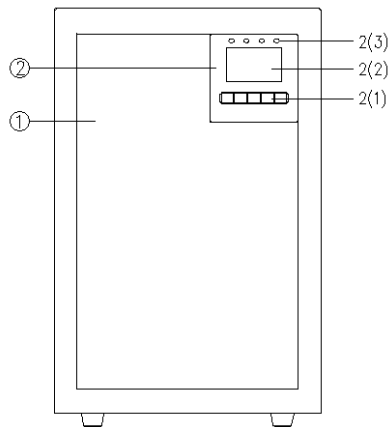

Tower UPS
6-10kVA C model

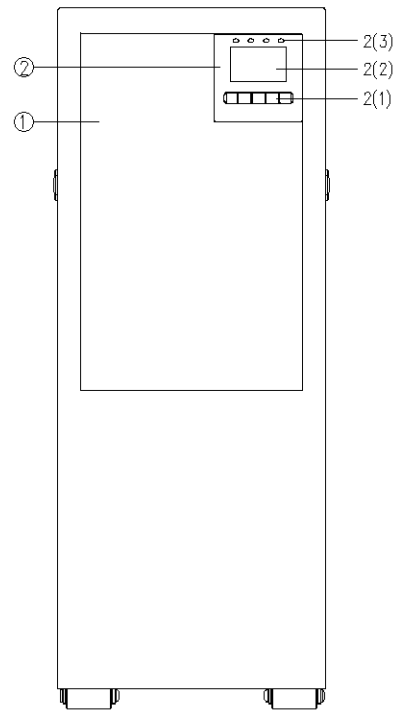

Tower UPS
6-10kVA B model

Rearview

- | | |
|---|--|
| 1. Intelligent slot | 8. RJ45 (for EBM detect) |
| 2. RS232 | 9. AC Input /Output port (Terminal Block) |
| 3. Ethernet port (RJ45, for IoT function) | 10. Input switch |
| 4. USB | 11. External battery port |
| 5. Wireless (HDMI, For IoT function) | 12. Maintenance bypass switch (optional, default is yes) |
| 6. RPO& DRY in/out | |
| 7. Parallel Slot | |

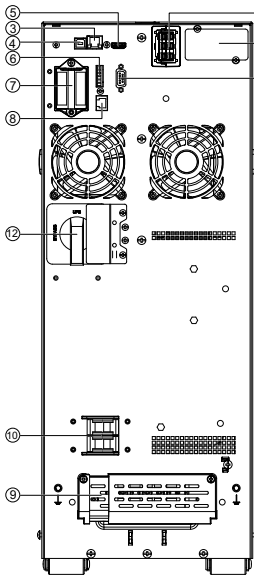

C650-060-B

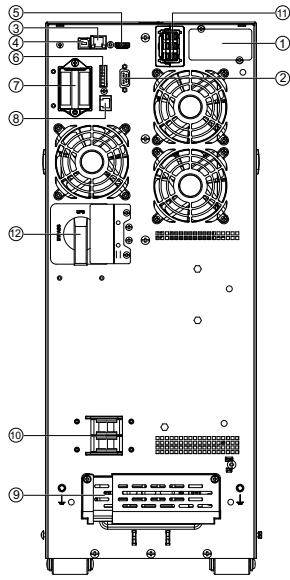

C650-100-B

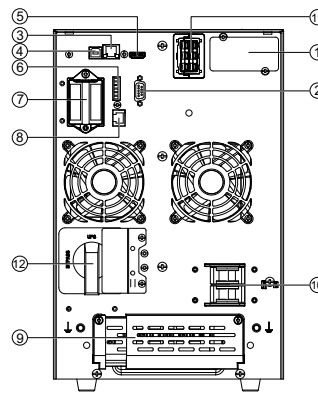

C650-060-C

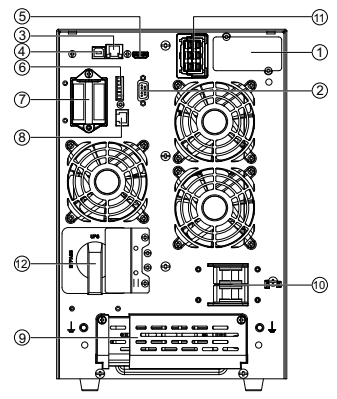

C650-100-C

EBM (EXTERNAL BATTERY MODULE)

FRONT VIEW

1. Ventilation area
2. EBM label

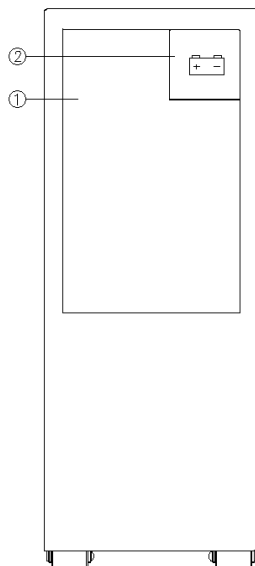

1. EBM port 1
2. EBM port 2
3. Fuse board cover (replace EBM fuse)
4. EBM detection Box (RJ45 port)

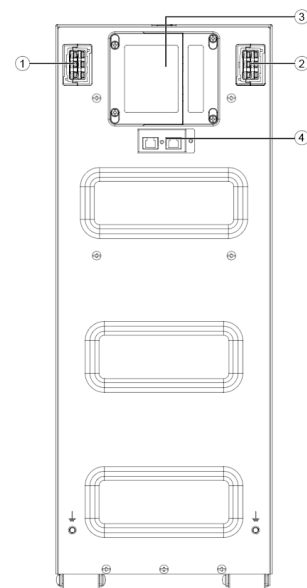

2.2.2 C650R Rack model:

UPS module

Front view

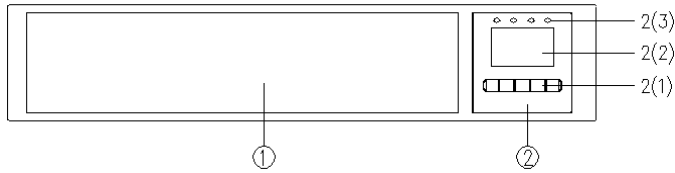

1. Ventilation area

2. LCD Modular, including 2(1) ---Button, 2(2)---LCD screen, 2(3)---LED indicator

Rearview

- | | |
|---|--|
| 1. INTELLIGENT SLOT | 7. PARALLEL SLOT |
| 2. RS232 | 8. RJ45 (for EBM detect /RT MBP detect) |
| 3. Ethernet port (RJ45, for IoT function) | 9. AC Input /Output port (Terminal Block) |
| 4. USB | 10. Breaker of input (only for 1-1 model, optional, default is no) |
| 5. Wireless (HDMI, For IoT function) | 11. External battery port |
| 6. RPO& DRY in/out | |

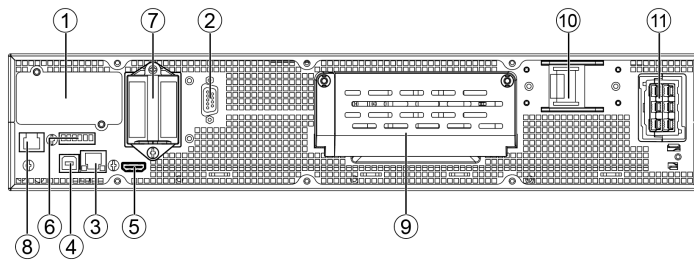

EBM (EXTERNAL BATTERY MODULE)

Front view

1. EBM label area
2. EBM label

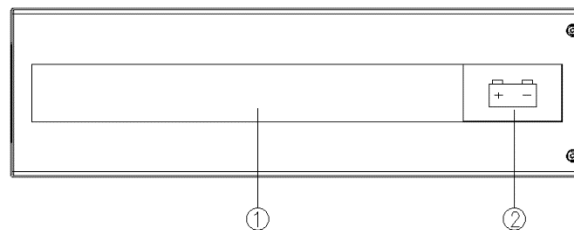

Rearview

1. Fuse board cover (replace EBM fuse)
2. EBM port 1
3. EBM port 2
4. EBM detection Box (RJ45 port)

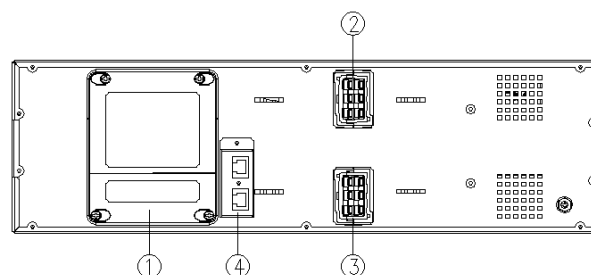

3. INSTALLATION

It is recommended to move the equipment to the installation site by using a pallet jack or a truck before unpacking.

The system may be installed only by qualified electricians by applicable safety regulations.

The EBM cabinets are heavy, please install it with at least two people.

3.1 UNPACKING AND INSPECTING



Unpacking the unit in a low-temperature environment may cause condensation to occur in and on the cabinet. Do not install the unit until the inside and outside of the unit are absolutely dry (hazard of electric shock).

If any equipment has been damaged during shipment, keep the shipping cartons and packing materials for the carrier or place of purchase and file a claim for shipping damage. If you discover damage after acceptance, file a claim for concealed damage.

Tower 6/10 kVA C model

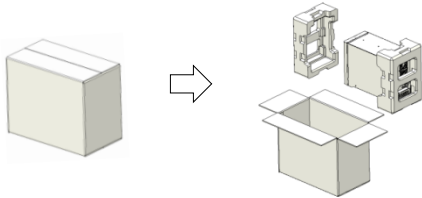

Tower 6/10kVA B model

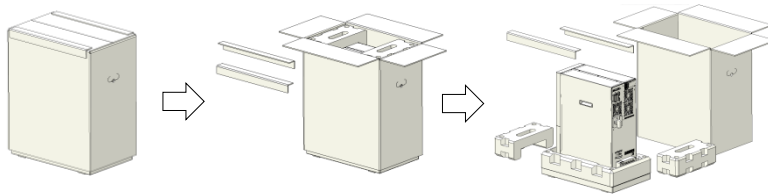

Tower EBM

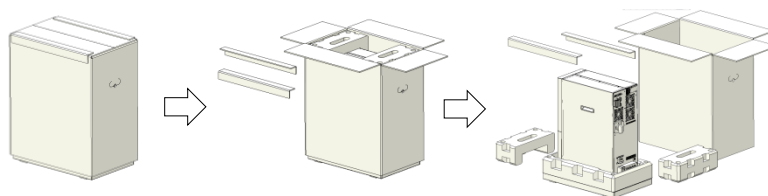

Rack UPS

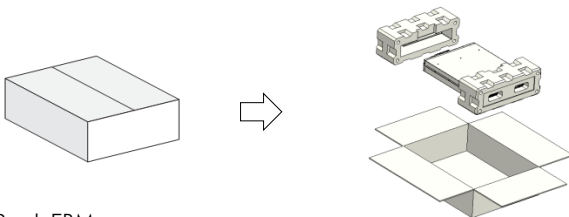

Rack EBM

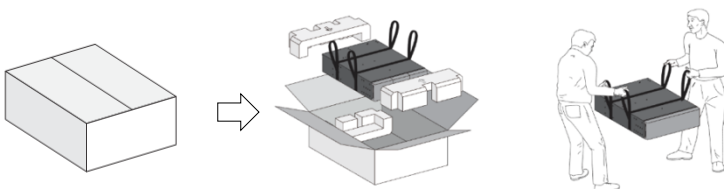

Note:

The cabinet is heavy, please see the spec weight provided on the carton/label.

Do not lift the unit by the front panel or rear panel.

Discard or recycle the packaging responsibly or store it for future use.



Packing materials must be disposed of in compliance with all local regulations concerning waste.

3.2 CHECKING THE ACCESSORY KIT

Verify that the following additional items are included with the unit.

Tower model:

	Tower			Rack		
	C650-060-B C650-100-B	C650-100-C C650-100-C	EBM	C650R-060-C C650R-100-C	C650R-060-C C650R-100-C	EBM
Battery cable		○	√		○	√
EBM detection cable			√			√
USB cable	√	√		√	√	
RS232 cable	○	○		○	○	
Parallel cable	○	○		○	○	
Tower foot	√	○	√	√	√	
Quick start (EBM)			√			√
User manual (UPS)	√	√		√	√	
Extension plate of Tower foot						√
Rack ear				√	√	√
Rack rail kit				○	○	○

Note : √--- Standard configuration; ○---Optional, default is Not configured.

3.3 MECHANICAL INSTALLATION

3.3.1 Tower model

To keep air flowing freely, it is recommended to keep a clearance with 500mm space both at the front and rear side of the UPS.

UPS model

1. Place the unit on a flat, stable surface in its final location,
2. Install 'tower foot' (if configured): remove side's screw from the unit, then install 'tower foot'.
3. Install the unit to ground(optional): place 4pcs bolts (M8 is recommended) to the final location, bolt's position please refer to below, then fix the unit to the bolts.

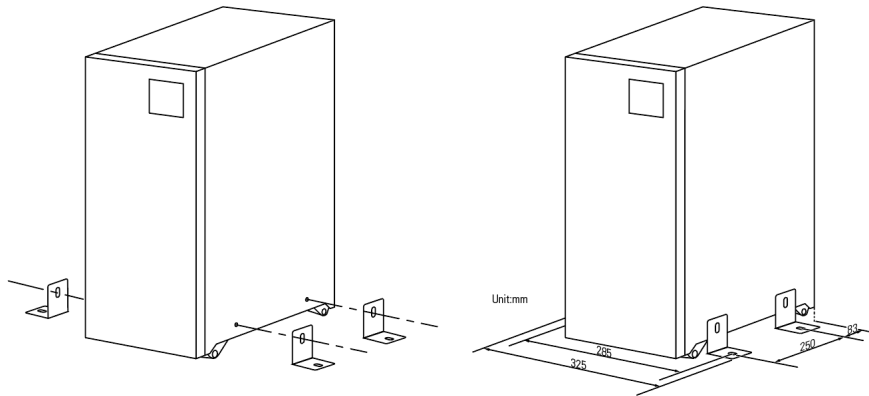

EBM Model

EBM installation steps are the same as UPS as above.

It is recommended to place EBM modular to UPS's left side.

3.3.2 Rack model

Rack models support 2 installation modes: Rack installation and Tower installation.

1. To keep good ventilation, please keep a free space of at least 500mm at least at the front & rear panels of modules.
2. Do not carry by the front or rear panel of the module during installation.

RACK INSTALLATION

This procedure is suitable for 19-inch rack cabinet installation, it is recommended that the depth of the cabinet be no less than 800mm.

UPS model

Identify the final position and keep '2U' space for this installation.

1. Install the rail kit (if configured). This rail kit is '2U' & with screw holes (M5)', the depth of the rail kit is: 443-773 mm.

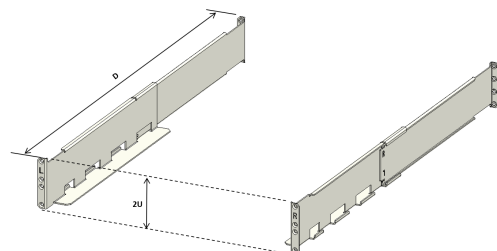

Fasten the rail kit to the cabinet with 8pcs M5 screws + washers (as below):

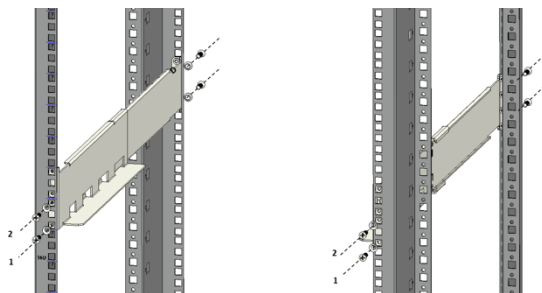

2. Install 'Rack ear' to the unit by the M4 screws (flat head)

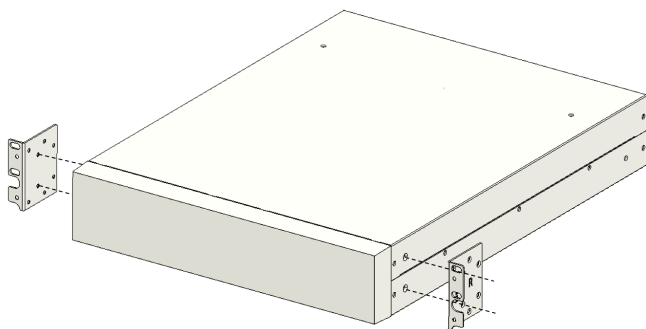

3. Slide the unit into 'rail kit' and ensure 'rack mounting screw' is tight.

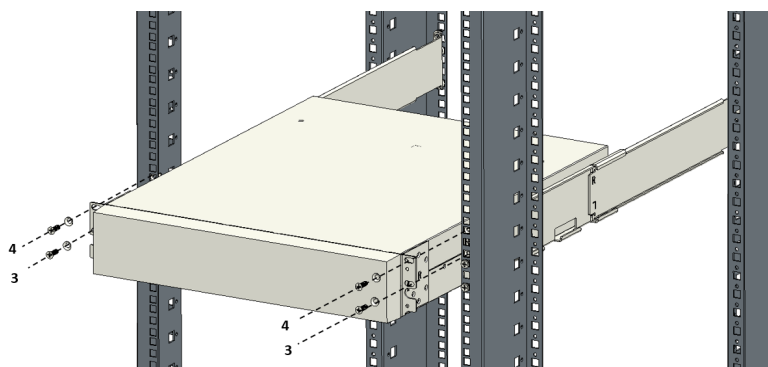

TOWER INSTALLATION

UPS model

1. Rotate the LCD Screen to tower orientation.

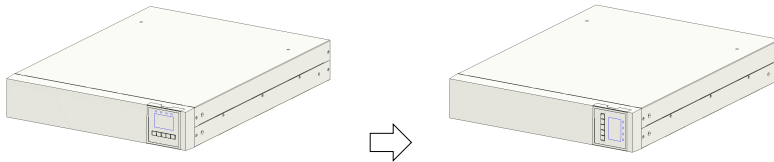

2. Set up the 'Tower foot', then place the unit into 'Tower foot'.

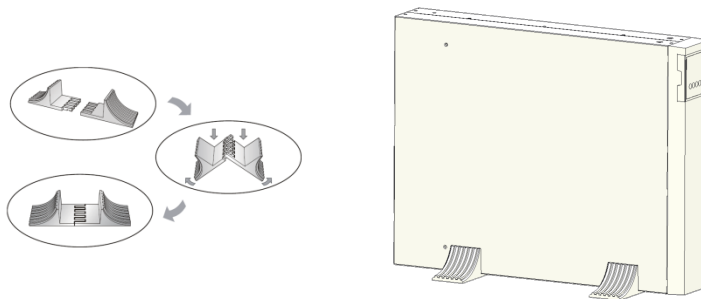

EBM model

1. Set up the 'Extension plate' as below and install it to 'Tower foot' from UPS.
2. Place the UPS & EBM into 'Tower foot' individually: Place the EBM module to UPS's right side and align with the front panel.

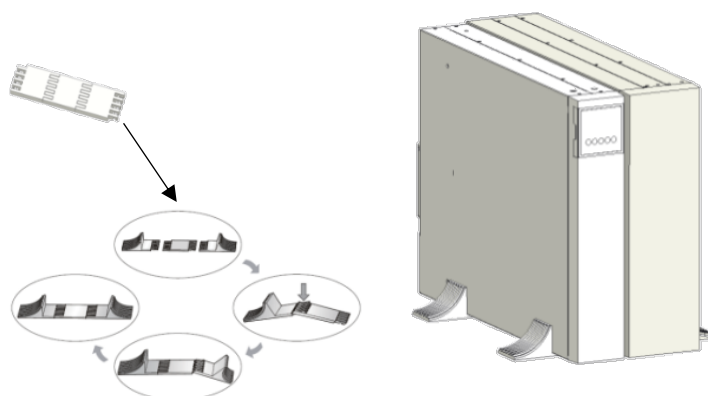

3.4 Power cables connection

This chapter introduces how to wire AC IN/OUT cable to UPS in different modes, and UPS connection with EBM/MBP.

3.4.1 Input /Output wiring specifications

Before wiring UPS, upstream breaker and backfeed contactor should be configured to avoid power backfeed to utility. A "back feed voltage danger" warning label should be added to the backfeed contactor or device. Backfeed contactor rating current should be larger than UPS rating input current.

The below figures show the wiring system of UPS input and output.

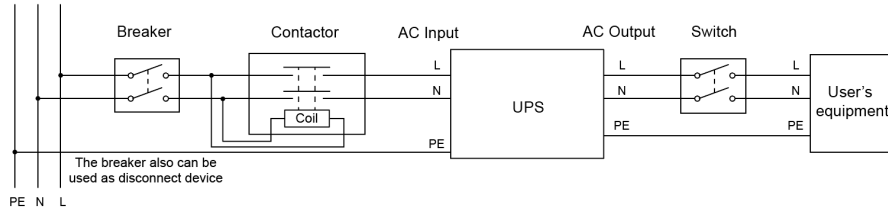

Single phase input system

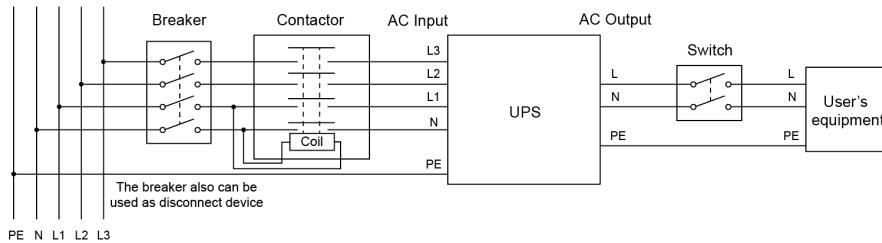

Read the Safety instructions and adhere to local wiring regulations regarding back feed protection requirements.

Recommended cable minimum cross-sectional:

Model	C650-060-C	C650-100-C
Protective earthing conductor	10mm ²	10mm ²
Input L, N cable	6mm ²	10mm ²
Output L, N cable	6mm ²	10mm ²
Battery cable	6mm ²	10mm ²

The length of the output cable is recommended not to exceed 10 meters, otherwise, it may cause radio interference. If the length of the output cable is over 10 meters requests, please contact distributors/agents for details.

3.4.2 Wiring for AC Cable (AC source to UPS)

High leakage current:



Earth connection essential before connecting supply.



This type of connection must be carried out by a qualified electrical person.

Before carrying out any connection, check that the upstream protection devices (Normal AC source and Bypass AC source) are open "O" (Off).

Always connect the ground wire first.

1. Remove the cover of the terminal block.
2. Connect the AC cable to terminal blocks:

TOWER UPS

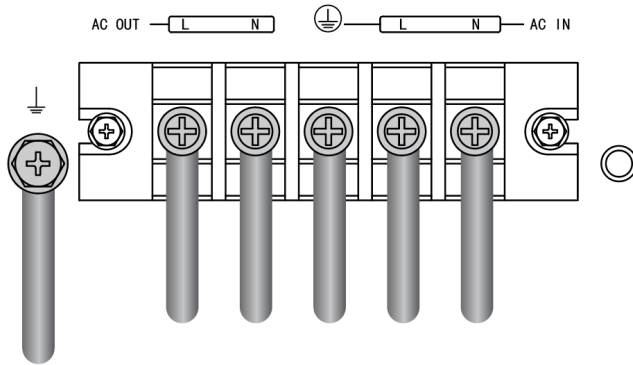

RACK UPS

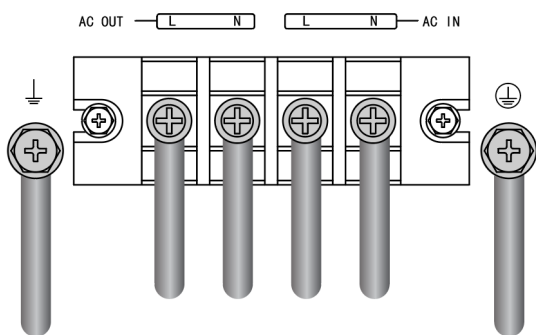

To ensure the cables are well fixed, it is recommended to tie these cables to the convex of the rear panel.

3.4.3 Wiring with external battery module (C650 / C650R EBM) (DC source to UPS)



1. Make sure the UPS is completely off before connecting or disconnecting the EBM.
2. Before connecting the EBM, make sure that the EBM specification is compatible with the UPS configuration.
3. Do not reverse the polarity of the external battery.

- Connect with the configured EBM:

Connect EBM to UPS with 'Battery cable' and 'EBM detection cable'.

TOWER EBM

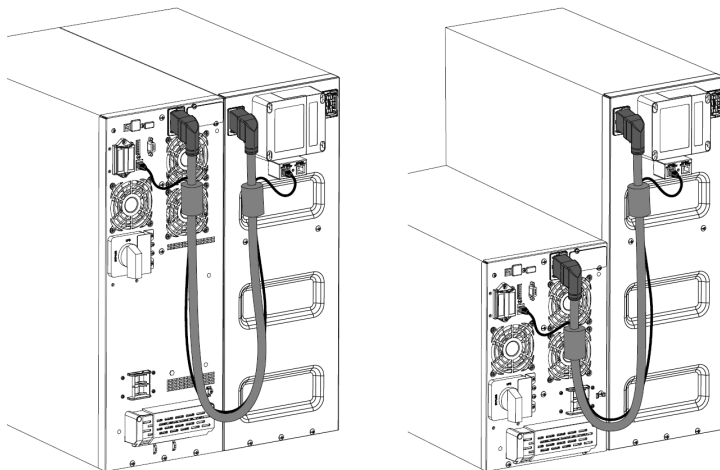

Note:

1. Extended runtime with up to 6 Extended Battery Modules (EBMs) per UPS.
2. To extend more than 2 EBMs, additional ground wires (10mm² cross-sectional area) are required.

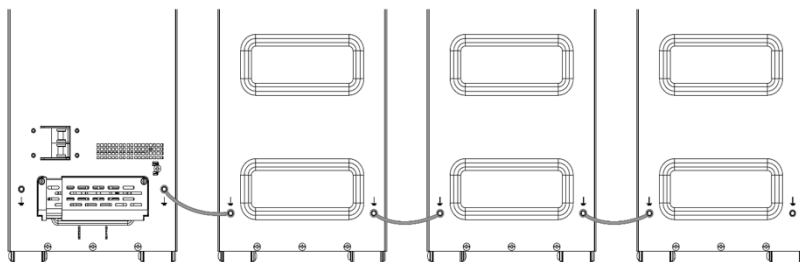

RACK EBM

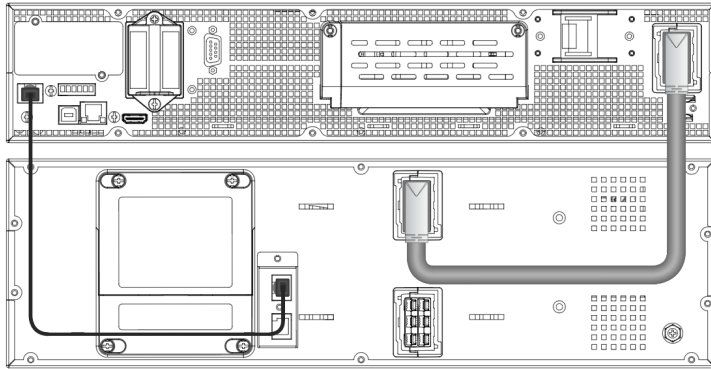

Note:

Extended runtime with up to 6 Extended Battery Modules (EBMs) per UPS.

Connect with user's own EBM:

Connect EBM to UPS with 'battery cable' (optional)

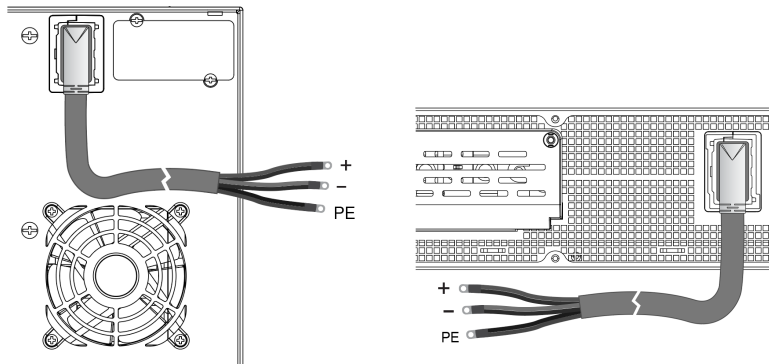

Tower model

Rack model

Note:

1.If an additional battery cable is needed for installation, it must follow cable specification and the maximum length of battery cable 10 meters for application.

2.If a length of battery cable over 10 meters is required, please contact distributors/agents for details.

3.4.4 Wiring with Rackmounted bypass

Rackmount bypass is an optional extra, to implement the maintenance bypass switching function to ensure that the output of the system is not affected during the UPS maintenance.

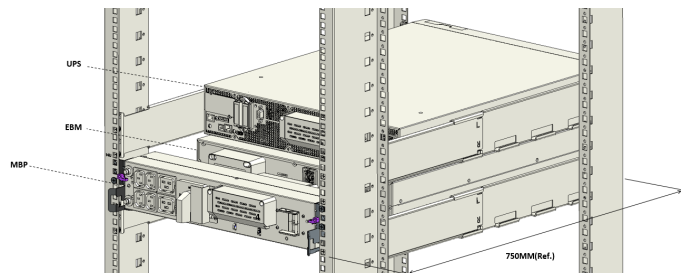

4. PARALLEL SYSTEM INSTALLATION AND OPERATION (OPTIONAL)

If your UPS is configured with the parallel function, up to 3 UPS systems can be connected in parallel to configure a sharing and redundant output power.

In parallel, the mechanical installation for each module is the same as the single system. For more details, please refer to Chapter 3.3.

Parallel system AC cable diagram:

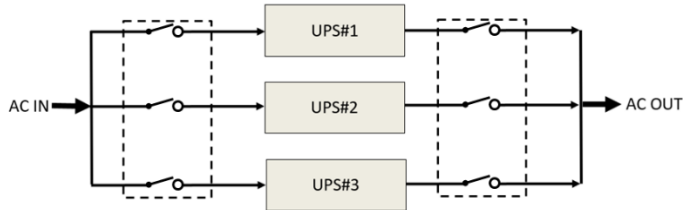

4.1 WIRING FOR AC CABLE

Tower model parallel system

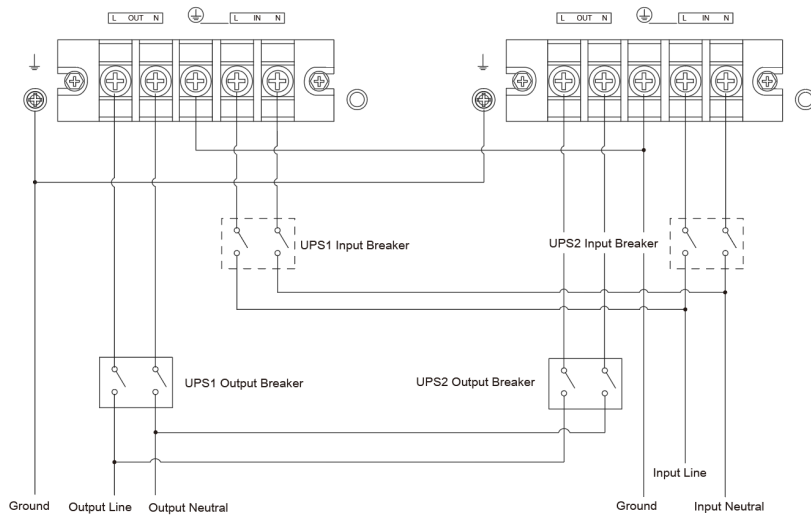

Rack model parallel system

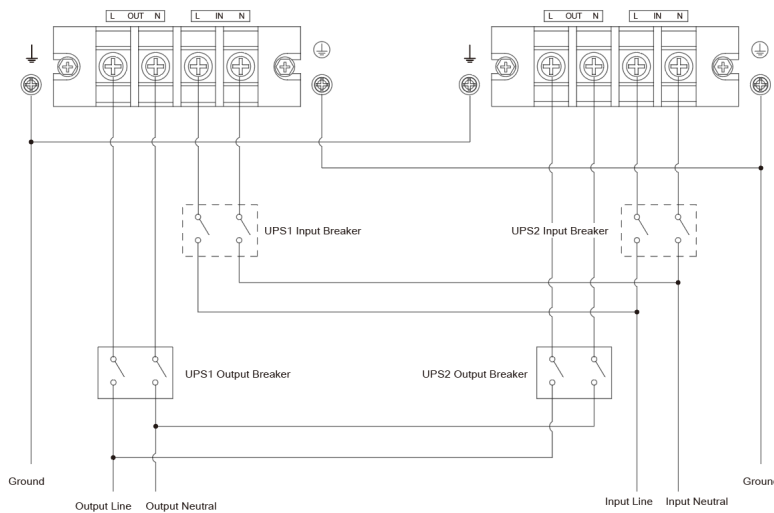

4.2 WIRING FOR PARALLEL SIGNAL CABLE

Parallel signal cable connection diagram:

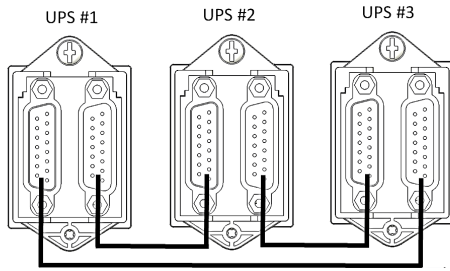

Remove the cover of 'parallel box', then connect each UPS one by one with the 'parallel cable', make sure the cable is screwed to the parallel port tightly.

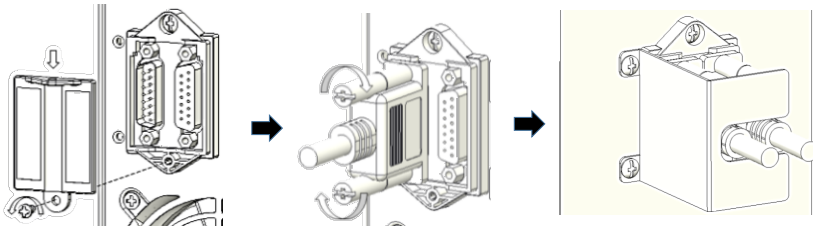

It is recommended to lock the 'parallel cable' (as above) for preventing the parallel ports from suffering an unexpected pulling force and causing the parallel system fault.

4.3 PARALLEL SYSTEM OPERATION

1. Ensure the output breakers of each UPS is open then turn on the input breakers for the parallel UPS.
2. Press the ϕ button continuously on one UPS of the system, then the system will start to turn on and enter line mode.
3. Regulate the output voltage of each UPS separately, and check if the output voltage difference is less than 0.5V among the parallel system. If the difference is more than 0.5V, the UPS need to be calibrated.
4. If the output voltage difference is less than 0.5V, press ϕ button continuously on one UPS of the system and the system will turn off. Turn off the input breakers to let UPS shut down. Then switch on the output breakers for all the UPS.
5. Turn on the input breakers for the parallel UPS. Pressing ϕ the button continuously for one UPS of the system, then the system will start to turn on and enter line mode and the system will work normally in parallel.

5. OPERATION

5.1 LCD PANEL



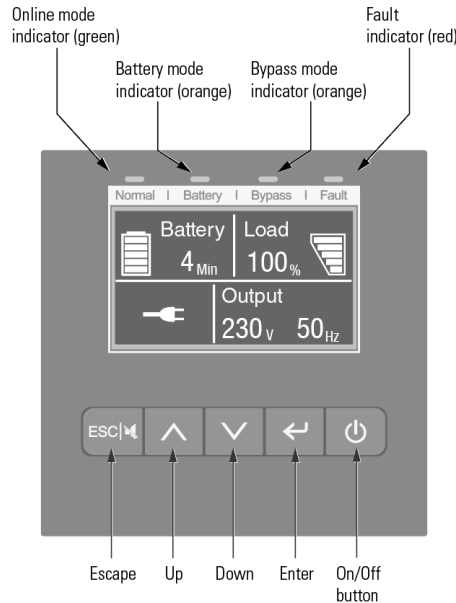

The UPS has a five-button graphical LCD. It provides useful information about the UPS itself, load status, events, measurements and settings.



THE LED

Indicator	Status	Description
Normal Green	On	The UPS is operating normally on Online or on High Efficiency mode.
Battery Orange	On	The UPS is in Battery mode.
Bypass Orange	On	The UPS is in Bypass mode.
Fault Red	On	The UPS has an active alarm or fault. Please refer to section 8.1 Trouble shooting for more information

THE BUTTONS

The button	Function	Illustration
	Power on	Press the Button for >100ms & < 1s will power on the UPS in standby.
	Turn on	When the Unity is powered on, press the button for >3s can turn on the UPS
	Turn off	Press the button > 4s can turn off the UPS
	Scroll up	Press to scroll up the menu option
	Scroll down	Press to scroll down the menu option
	Enter menu	Select/Confirm the current selection
	Exit the present menu	Press to exit present menu to Main menu or the higher-level menu without changing a setting
	Mute buzzer	Press the button to mute the buzzer temporarily, once new warning or fault is active, buzzer will work again

THE BUZZER

The buzzer	General Meaning
1 beep every 2 minutes	Load supplied on bypass
1 beep every 4 seconds	Load supplied on battery If battery low, beep every second
1 beep every second	General warning active
2 beeps every second	Overload warning
Continuous	Fault active



BACKLIGHT

After 10 minutes of inactivity, the LCD backlight will automatically dim. Press any button to restore the screen.

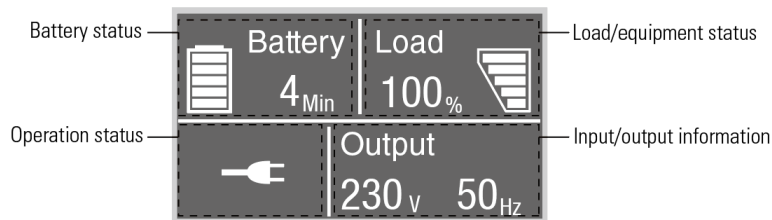



5.2 LCD DESCRIPTION



Operation status	Cause	Description
	Standby mode	The UPS is Off without output.
	Online mode	The UPS is operating normally and protecting the equipment.
 1 beep every 4 seconds	Battery mode	A utility failure has occurred, and the UPS is powering the equipment with battery. Prepare your equipment for shutdown.
 1 beep every 1 seconds	Battery mode with battery low	This warning is approximate, and the actual time to shutdown may vary significantly.
	High Efficiency mode	When the mains are lost or abnormal, the UPS will transfer to Line mode or Battery mode and the load is supplied continuously.
	Converter mode	The UPS would free run with fixed output frequency (50Hz or 60Hz). The output maximum power and maximum charging current should be derating to 60% in converter mode.
	Bypass mode	Overload or fault has occurred, or a command has been received, and the UPS is in Bypass mode.
	Battery test	UPS is executing a battery test
	Battery fail	The UPS detects bad battery or battery disconnected

	Overload	Some unnecessary loads should be cut off to reduce the load.
	Fault mode	Some fatal problems happened.
	Parallel mode	UPS is working in parallel mode

5.3 DISPLAY FUNCTIONS

Use the two middle buttons ( and ) to scroll through the menu structure. Press the enter () button to select an option. Press the Esc () button to cancel or return to the previous menu.

When starting the UPS, the display is the default UPS status summary screen.

Main menu	Submenu	Display information or Menu function
UPS status		UPS mode, IoT status, date/time, battery status, parallel information and current alarms
Event log		Displays the events and faults stored
Measurements		[Load] W, VA, A, P%, [Input L1/Output] V, Hz, [Input L2/Input L3] V, Hz (if they exist), [Battery] %, min, V, EBM, [DC Bus] V, [Temperature] °C
Control	Load segment	Load segments enable or disable
	Start battery test (Single mode)	Starts a manual battery test in stand-alone mode Or starts a single battery test in parallel mode
	Single battery test (parallel mode)	
	Parallel UPS battery test (parallel mode)	Starts a manual battery test in parallel mode
	Single UPS turn off (parallel mode)	Operate this machine to exit parallel connection
	Reset fault state	Clear active fault
	Reset event list	Clear events and faults
	Reset com card / Reset IoT	Reset IoT and Modbus TCP function inside UPS
	Restore factory settings	Restore to default factory settings
Settings		Refer to User settings
Identification		[Model name], [Serial number], [firmware version], [comm card firmware], [IP/MAC address]

5.4 USER SETTINGS

Submenu	Available settings	Default settings
Password	Can be changed by user	4314
Language	English, Italiano, Français, Deutsch, Español, Русский, Polski, 简体中文	English
User password	[Enabled, ****], [Disabled]	Enabled
Audible alarms	[Enabled], [Disabled]	Enabled
Output voltage	[220V], [230V], [240V]	[230V] [240V] for AU
Output frequency	[Autosensing], [converter 50Hz, 60Hz]	Autosensing
High efficiency	[Disabled], [Enabled]	Disabled
Auto bypass	[Disabled], [Enabled]	Enabled
Start/Restart	Cold start: [Disabled], [Enabled]	Enabled
Site wiring fault	[Enabled], [Disabled]	Disabled
Overload pre-alarm	[50%~105%]	105%
External battery	[Auto detection], [Manual EBM: 0~6], [Manual Ah: 0~300Ah]	Auto detection 0 EBM 0 Ah
Charger current	1-4A for 6-10k 2-12A for 6-10KS	1.4A for 6K 2A for 10K
Dry in signal	[Disabled], [Remote on], [Remote off], [Forced bypass]	Disabled
Dry out signal	[Load powered], [On bat], [Low bat], [Bat open], [Bypass], [UPS OK]	Bypass
Ambient temperature alarm	[Enabled], [Disabled]	Enabled
Battery remaining time	[Enabled], [Disabled]	Enabled
Date and time	dd/mm/yyyy hh:mm	01/01/2020 00:00
LCD contrast	[0-100%]	50%
Modbus TCP	[Enabled], [Disabled]	Disabled
IoT Enable	[Yes], [No]	No



Note: if the utility power is an IT earthing system, the site wiring fault function should be disabled.

5.5 STARTING THE UPS WITH UTILITY

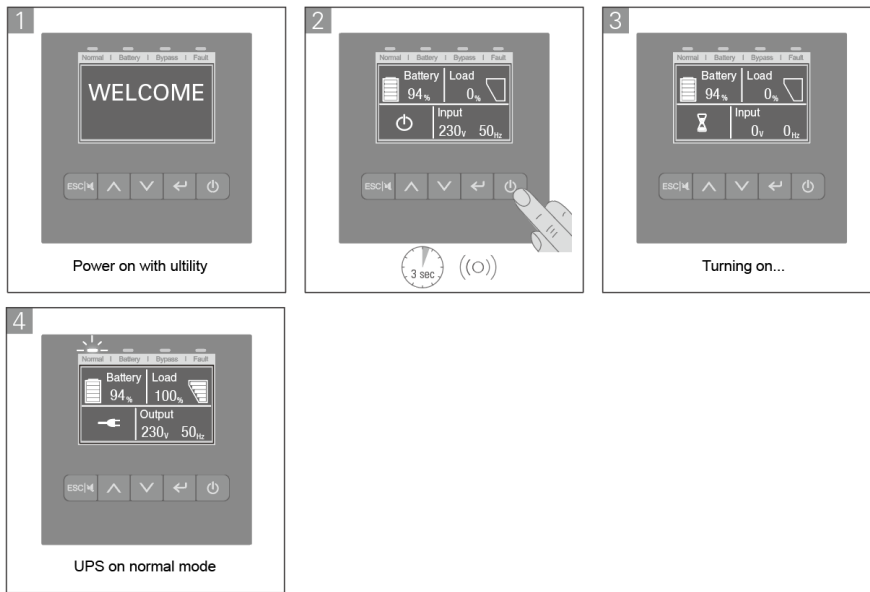

5.6 STARTING THE UPS ON BATTERY

Before using this feature, the UPS must have been powered by utility power with output enabled at least once.

Battery start can be disabled. See the 'Cold start' setting in 'start/restart'.

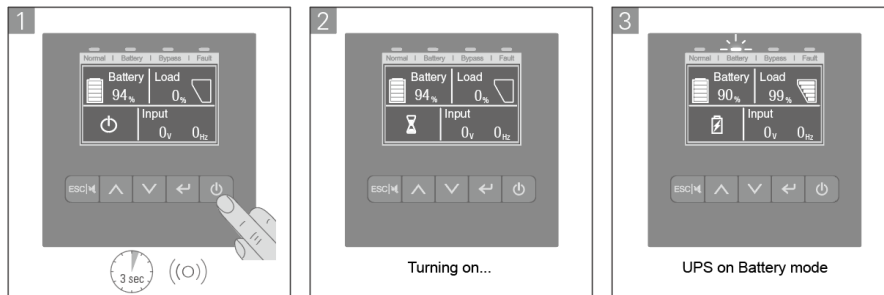

5.7 UPS SHUTDOWN

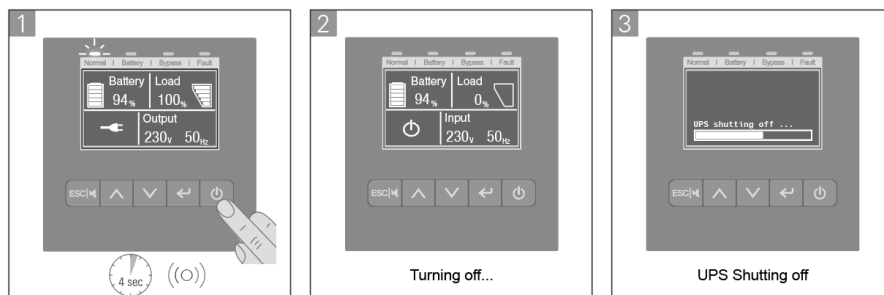

6. COMMUNICATION

6.1 RS232 AND USB

1. Connect the communication cable to either the serial or USB port on the computer.
2. Connect the other end of the communication cable to the RS232 or USB communication port onto the UPS.

6.2 UPS REMOTE CONTROL FUNCTIONS

- Remote Power Off (RPO)

When RPO is activated, UPS will cut off output immediately, and continues to alarm

RPO	Comments
Connector type	1.3mm Maximum wires
External breaker specification	60 V DC/30 V AC 20 mA max

Reset:

1. Check the RPO connector status:
2. Clear fault state through LCD.

- Dry In

Dry in function can be configured (see Settings > Dry in).

Dry in	Comments
Connector type	1.3mm Maximum wires
External breaker specification	60 V DC/30 V AC 20 mA max

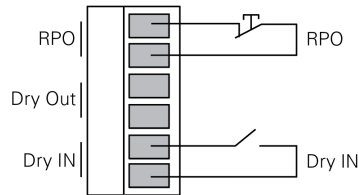

Dry Out

Dry out is the relay out, dry out function can be configured (see Settings > Dry out).

Dry out	Comments
Connector type	1.3mm Maximum wires
Inner Relay specification	24Vdc/1A

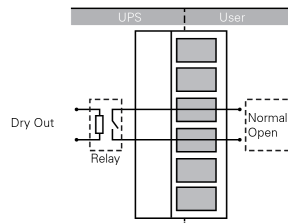

6.3 IOT

The built-in ethernet port and WLAN, C-WIFI, (optional accessory) port enables market-leading and easy-to-use IoT solutions for:

- CertaUPS mobile app which allows you to remote monitor UPS(s) and keep informed about critical UPS events always.
- Remote report UPS faults and status from APP or registered APP account (Email address).
- Automatic UPS and battery warranty alert from APP or registered APP account (Email address).

IoT Connection

Wired network connection

1. Connect UPS to the router or switch with a network cable.
 - Please use CAT6 shielded network cable.
 - Make sure your IT settings can access the public network and Microsoft Azure Cloud.
2. Enable the IoT function in LCD (see Settings -> IoT)
3. Search for the CertaUPS App from Google Play Store or Apple APP store, download and install.
4. Open the app, register an account, log in, follow the instructions of the app.
5. Tap  on the upper right corner, scan the SN barcode on the UPS label to add a device.

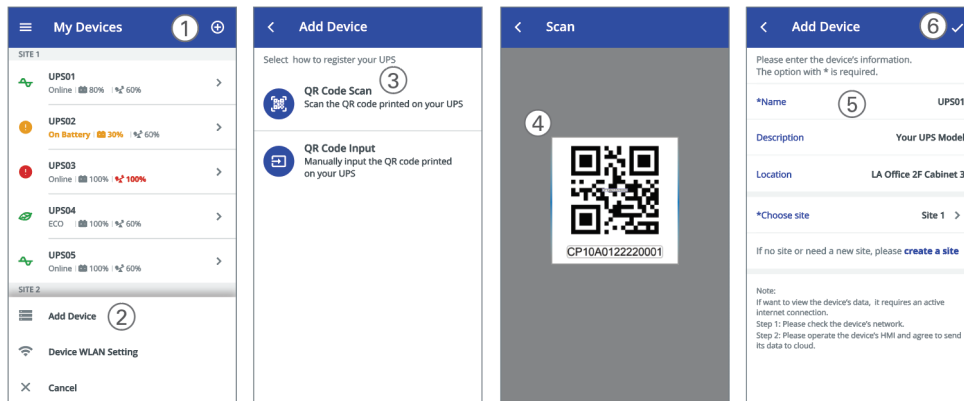

 For more detailed information and Q&A about the IoT and APP, please refer to the HELP menu in the app.

- Wireless network connection

The wireless module is optional, please contact your local distributor for details.

6.4 Modbus TCP

Built-in Ethernet port offers Modbus TCP features to facilitate remote monitoring of the UPS into your software. Contact your distributor or CertaUPS partner for protocol details.

6.5 Intelligent Card (optional)

The Network Management Card (C-NMC) allows the UPS to communicate with monitoring devices by utilising network connectivity. The C650 series has one available expansion bay for the following connectivity cards:

- NMC/SNMP Card (C-NMC) – this interface card provides SNMP and HTTP capabilities as well as monitoring through a Web browser interface using RJ45 10/100Mbps over TCP/IP.
- C-Relay card - for RS485 communication protocol. Please contact your CertaUPS partner for details.

6.6 SOFTWARE

6.6.1 Winpower

The C650 series is compatible with WinPower which is an open source, online UPS monitoring and management software tool.

Key features:

- Power flow display for monitoring UPS status
- Scheduled system shutdown / restart
- Warning notification via E-mail / SMS / Windows system log*
- Scheduled UPS test
- Password security protection
- Remote monitor / control via LAN
- Safety to shutdown multi-system
- Selectable User Interface (Background)
- UPS parameter setting
- SNMP Central monitoring up to 1000 units
- Record logs for analysis
- Multi-language support: English, Italian, Turkish, Spanish, French, Portuguese, Polish, Thai, Germanic, Russian and Japanese.

*Requires a GSM modem (not supplied)

WinPower installation:

STEP ONE	Go to: http://www.ups-software-download.com/content/ups-download-software/download.html , download winpower
STEP TWO	Choose the operating system you need and follow the instruction described on the website to download the software.
STEP THREE	When downloading all required files from the internet, enter the product key: 511C1-01220-0100-478DF2A

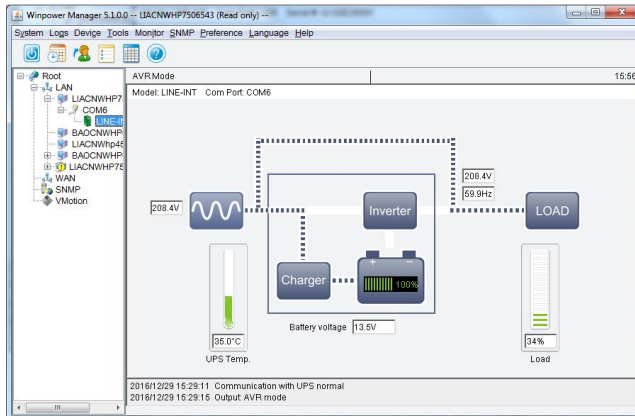

WHEN THE INSTALLATION IS COMPLETE, WinPOWER WILL APPEAR AS A GREEN PLUG ICON LOCATED IN THE SYSTEM TRAY, NEAR THE CLOCK.

FOR FURTHER GUIDANCE ON UPS MONITORING, PLEASE CONTACT YOUR CertaUPS PROVIDER OR VISIT WWW.CERTAUPS.COM

6.6.2 CertaUPS APP

WinPower View is a mobile app that allows you to centralise monitored UPS by connecting them to the cloud. Please download it from the Google Play Store or Apple APP store. Please refer to chapter 6.3 for IoT connection

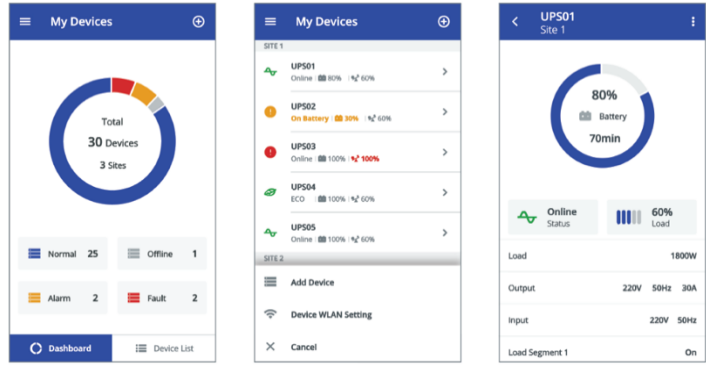

7. UPS MAINTENANCE

ADOPTING A PREVENTATIVE MAINTENANCE SCHEDULE IS CRITICAL TO ACHIEVING OPTIMUM UPS PERFORMANCE

UPS CARE

For the best preventive maintenance:

Keep the area around the equipment clean
Keep the equipment free from dust
Ensure the equipment is positioned in a well-ventilated area
For maximum battery life keep the equipment at an ambient temperature of 20-25°C (77°F max)
Carry out regular environmental and battery checks



The batteries are rated for a 3–5-year service life. The service life varies depending on the frequency of usage and ambient temperature. Batteries used beyond expected service life will often have severely reduced runtimes. Replace batteries at least every 4 years to keep units running at peak efficiency and prevent failure.

7.1 TRANSPORTING THE UPS



THE INTERNAL UPS BATTERIES MUST BE DISCONNECTED BEFORE TRANSPORT



The following procedure should be performed or supervised by personnel knowledgeable about batteries and the required precautions. Keep unauthorised personnel away from batteries. If the UPS requires any type of transportation, the batteries must be disconnected (but not removed) before the unit is transported:

Verify that the UPS is off and disconnected from mains power
Place the UPS on a flat stable surface with the front of the cabinet facing you
Remove the UPS front cover
Disconnect the internal battery connectors
Replace the UPS front cover

To avoid damage and to prevent DOA's always use a reputable courier for all equipment transportation.

7.2 STORING THE UPS

UPS BATTERIES MUST BE RECHARGED EVERY SIX MONTHS. ALWAYS CHECK THE BATTERY RECHARGE DATE ON THE SHIPPING CARTON BEFORE USE.

Where UPS equipment is stored for a long period, the batteries must be recharged every six months. The optimal storage VDC for VLRA batteries, depending on the environment is between 20-40%. This can be achieved by connecting the UPS to mains power.

DO NOT Store the equipment in a warm, damp, dusty environment	
DO NOT Use the equipment if the batteries have not been recharged/if the recharge date exceeds six months	
DO NOT Expose the UPS to direct sunlight or source of heat	

DO Store the equipment in a cool, dry, clean environment	
DO Ensure the batteries are recharged every six months for a minimum of 48 hours	
DO Ensure EBMs are recharged every six months for a minimum of 3 hours	

7.3 BATTERY REPLACEMENT



DO NOT DISCONNECT THE BATTERIES WHILE THE UPS IS IN BATTERY MODE



CONSIDER ALL WARNINGS, CAUTIONS, AND NOTES BEFORE REPLACING BATTERIES



ELECTRIC ENERGY HAZARD. DO NOT ATTEMPT TO ALTER ANY BATTERY WIRING OR CONNECTORS.

DO NOT Allow unauthorised personnel near the batteries. Servicing should be performed by qualified, knowledgeable personnel only	
DO NOT Dispose of batteries in a fire. Batteries may explode when exposed to flame	
DO NOT Open or modify the battery or batteries in any way. Released electrolyte is harmful to the skin and eyes and may be extremely toxic	
DO NOT Attempt to alter any battery wiring or connectors. Attempting to alter wiring can cause injury	

DO Ensure personnel servicing the batteries are all knowledgeable on the required precautions for battery servicing	
DO Replace the batteries with the same type and number of batteries or battery packs	
DO Dispose of the batteries responsibly. Please refer to local regulations and disposal requirements	
DO Determine if the battery is inadvertently grounded. If inadvertently grounded, remove source from ground. Contact with any part of a grounded battery can result in electrical shock. The likelihood of shock can be reduced if grounds are removed during installation and maintenance (applicable to equipment and remote battery supplies not having a grounded supply circuit).	
DO Disconnect charging source prior to connecting or disconnecting battery terminals	

Batteries can present a risk of electrical shock or burn from high short circuit current. Observe the following precautions:

Remove watches, rings, or other metal objects
Use tools with insulated handles
Do not lay tools or metal parts on top of batteries
Wear rubber gloves and boots

7.4 REPLACING THE EBM



THE EBM IS HEAVY AND REQUIRES A MINIMUM OF 2 PEOPLE TO LIFT INTO RACKING.

For the C650 tower module: Turn the MBS to bypass and switch off the input and then replace the EBM(s).
 For the C650R rotation module: If a PDU is connected to the UPS, turn the MBS to bypass and switch off the input, it is then safe to replace the EBM(s). If a PDU is not connected to the UPS, turn off the UPS and then replace the EBM.

To replace the EBM(s):

1. Unplug the EBM power cable and battery detection cable from the UPS. If additional EBM(s) are installed, unplug the EBM power cable from each EBM
2. Replace the EBM(s)



A SMALL AMOUNT OF ARCING MAY OCCUR WHEN CONNECTING AN EBM TO THE UPS. THIS IS NORMAL AND WILL NOT CAUSE SHOCK. INSERT THE EBM CABLE INTO THE UPS BATTERY CONNECTOR QUICKLY AND FIRMLY

- Plug the EBM cable(s) into the battery connector(s)
- Verify that the EBM connections are secure, and that adequate bend radius and strain relief exist for each cable
- Connect the EBM cable to the UPS

To test new batteries:

1. Charge the batteries for 48 hours.
2. Press on the menu of "Control".
3. Select Control
4. Select Single battery test

The UPS starts a battery test if:

- The batteries are fully charged
- The UPS is in Normal mode with no active alarms
- Bypass voltage is acceptable

During the battery test, the UPS transfers to Battery mode and discharges the batteries for 10 seconds. The front panel displays  and the percentage of the test completed.

7.5 RECYCLING A UPS



CONTACT YOUR LOCAL RECYCLING OR HAZARDOUS WASTE CENTRE FOR INFORMATION ON PROPER DISPOSAL OF THE USED EQUIPMENT.

DO NOT dispose of the battery or batteries in a fire. Batteries may explode. Proper disposal of batteries is required. Refer to your regulations for disposal requirements.

DO NOT open or modify the battery or batteries. Released electrolyte is toxic and harmful to the skin and eyes.



DO NOT discard the UPS or the UPS batteries in the general waste. This product contains sealed lead-acid batteries and must be disposed of responsibly. For more information contact your local recycling centre.



DO NOT discard waste electrical or electronic equipment (WEEE) in the trash. For proper disposal contact your local recycling centre.

8. TROUBLESHOOTING

The C650 series is designed for durable, automatic operation. It also provides alerts whenever potential operating problems occur.

ALARMS SHOWN ON THE CONTROL PANEL DO NOT MEAN THAT THE OUTPUT POWER IS AFFECTED. INSTEAD THEY ARE PREVENTIVE ALARMS INTENDED TO ALERT THE USER

- Events are silent status information that is recorded into the Event log. Example = "AC freq in range".
- Alarms are recorded into the Event log and displayed on the LCD status screen with the logo blinking. Some alarms may be announced by a beep every 1 second. Example = "Battery low".
- Faults are announced by a continuous beep and red LED recorded into the Event log. Example = Out. Short circuit.

To check the Event log:

- By pressing  on the menu of "Event log".
- Scroll through the listed events or faults.
- The following table describes typical conditions.

8.1 ALARMS & FAULTS

TO REGISTER A FAULT PLEASE VISIT CERTAUPS.COM/SUPPORT/FAULT-REPORTING/

Use the following troubleshooting chart to determine the UPS alarm condition.

WARNING		
Problem Displayed	Possible cause	Remedy
On Maintain Bypass	Maintain bypass switch is open	Check the maintain bypass switch position.
Site Wiring alarm	Phase and neutral conductor at input of UPS system are reversed	Reverse mains power wiring.
No battery	Battery pack is not connected correctly	Do a battery test to confirm. Check the battery bank is properly connected to the UPS. Check the battery breaker is turn on or fuse OK.
Battery low	Battery voltage is low	When audible alarm sounding every second, battery is almost empty.
End battery life	The battery has reached the end of its life	Consult dealer if replace the battery
Power overload	Power requirements exceed the UPS capacity	Check the loads and remove some noncritical loads. Check if some loads are failed
Overload pre-alarm	The load exceeds the pre-set value	Check the loads or reset the pre-alarm value
Fan Lock	Fan abnormal	Check if the fan is running normally or fan detection cable disconnected
UPS temp. alarm	Inside temperature of UPS is too high	Check the ventilation of UPS and the ambient temperature.
Amb. temp. alarm	The ambient temperature is too high	Check the environment ventilation
Imminent shutoff	Insufficient battery backup time	Protect load equipment in time
FAULT		
Problem Displayed	Possible cause	Remedy
Inverter overload	Overload	Check the loads and remove some noncritical loads. Check if some loads are failed.
Bypass overload	Overload	Check the loads and remove some noncritical loads. Check if some loads are failed.
Out. short circuit	abnormally low impedance placed on its output and considers it a short circuit	Remove all the loads. Turn off the UPS. Check if UPS output and loads is short circuit. Ensure short circuit is removed before turning on again.
UPS temp. fault	Inside temperature of UPS is too high	Check the ventilation of UPS and the ambient temperature.
DC bus + or - too high	UPS internal fault, the + or -DC BUS voltage is too high	Consult dealer.
DC bus + or - too low	UPS internal fault, the + or -DC BUS voltage is too low	Consult dealer.
DC bus unbalanced	UPS internal fault, the voltage difference between DC Bus+ and DC bus- is too large	Consult dealer.
DC bus short circ.	UPS internal fault	Consult dealer.
Max inverter volt	UPS internal fault, the inverter voltage is too high	Consult dealer.
Min inverter volt	UPS internal fault, the inverter voltage is too low	Consult dealer.
ELSE CASES		
Problem Displayed	Possible cause	Remedy
No indication, no warning tone even though system is connected to mains power supply	No input voltage	Check the building wiring and input cable. Check if the input breaker is closed.
Green LED is not on even though the power supply is available	Inverter not switched on	Press On-Switch to turn on UPS.

Emergency supply period shorter than nominal value	Batteries are not fully charged / batteries defect	Charge the batteries for at least 12 hours and then check capacity.
--	--	---

8.2 SILENCING THE ALARM

- Press the ESC (Escape) button on the front panel display for 2 Seconds to silence the alarm.



Check the alarm condition and perform the applicable action to resolve the condition.



If an alarm status changes the alarm will need to be silenced again.

9. TECHNICAL DATA

9.1 BLOCK DIAGRAM

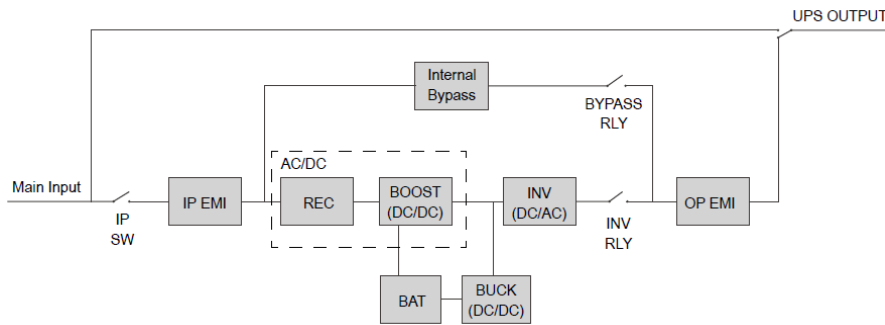

9.2 UPS SPECIFICATION

Tower UPS

Model	C650-060-B	C650-060-C	C650-100-B	C650-100-C
Capacity	6kVA/6kW		10kVA / 10kW	
INPUT				
Input Voltage Range	110VAC - 276VAC			
Rated Voltage	220/230/240VAC			
Frequency	50Hz/60Hz			
Frequency Range	45Hz-55Hz (50Hz system), 54Hz-66Hz (60Hz system) @ load>60%			
Power Factor	1			
Rated current (20pcs battery)	35A	45A	54A	63A
OUTPUT				
Voltage Regulation (AC Mode)	220/230/240V AC			
Rated Frequency	50 Hz / 60 Hz			
Power Factor	1			
Voltage accuracy	±1%			

Transfer Time Line <-> Battery	0ms			
Transfer Time INV<-> Bypass	0ms			
Wave form	Pure sine wave			
Short Circuit Current on Normal Mode	54A for 200ms max	113A for 200ms max		
Overload Capacity	105%-125% Load, 10 minutes transfer to Bypass; 125%-150% Load, 30 seconds transfer to Bypass; >150% Load, 0.5 seconds transfer to Bypass			
BATTERY				
Voltage	192 / 240V DC selectable			
Maximum EBM quantity	6			
CHARGER				
Charging Current (default)	1.4A	4A	2A	4A
Charging range	1~4A	2~12A	1~4A	2~12A
OTHER MODE				
CVCF	Yes (deterating to 60% load)			
HMI				
Display	Dot matrix LCD (optional segment LCD)			
Language	Multi-language			
USB	USB 2.0 with HID power device			
RS232	Yes (DB9)			
Dry in/out	1 programmable dry in; 1 programmable dry out			
RPO	Yes			
Intelligent Slot	Yes			
Network Card	Optional, C-NMC			
Modbus Card	Optional, C-Modbus			
Dry Contactor Card	Optional, C-Relay			
Wireless Module	Optional, C-WIFI			
IOT Ethernet Port	RJ45			
Monitoring Software	Winpower, CertaUPS App			
PHYSICAL				
Dimension (WxDxH) mm	225 x 416 x 589	225 x 416 x 354	225 x 416 x 589	225 x 416 x 354
Net weight (Kg)	58	14	69	16
IP Protection Level	IP20			
ENVIRONMENT				

Operating Temperature	0-40°C (derating 50% above 40°C) excluding batteries
Relative Humidity	0-95% (non-condensing)
Operating Altitude	0-3000m (the load derating 1 % every up 100m @1000~3000m)
Storage temperature (with battery)	-15°C - 40°C
Storage temperature (without battery)	-25°C - 55°C
Certification	CE, IEC/EN 62040, UKCA

Rack UPS

Model	C650R-060-B	C650R-060-C	C650R-100-B	C650R-100-C
Capacity	6kVA/6kW		10kVA / 10kW	
INPUT				
Input Voltage Range	110VAC - 276VAC			
Rated Voltage	220/230/240VAC			
Frequency	50Hz/60Hz			
Frequency Range	45Hz-55Hz (50Hz system), 54Hz-66Hz (60Hz system) @ load>60%			
Power Factor	1			
Rated current	35A	45A	54A	63A
OUTPUT				
Voltage Regulation (AC Mode)	220/230/240V AC			
Rated Frequency	50 Hz / 60 Hz			
AC Outlets	Terminal Block			
Maximum Power Factor	1			
Voltage accuracy	±1%			
Transfer Time Line <-> Battery	0ms			
Transfer Time INV<-> Bypass	0ms			
Wave form	Pure sine wave			
Short Circuit Current on Normal Mode	54A for 200ms max		113A for 200ms max	
Overload Capacity	105%-125% Load, 10 minutes transfer to Bypass; 125%-150% Load, 30 seconds transfer to Bypass; >150% Load, 0.5 seconds transfer to Bypass			
BATTERY				
Voltage	192 / 240V DC selectable			

Maximum EBM quantity	6			
CHARGER				
Charging Current (default)	1.4A	4A	2A	4A
Charging range	1~4A	2~12A	1~4A	2~12A
OTHER MODE				
CVCF	6C			
HMI				
Display	Dot matrix LCD (optional segment LCD)			
Language	Multi-language			
USB	USB 2.0 with HID power device			
RS232	Yes (DB9)			
Dry in/out	1 programmable dry in; 1 programmable dry out			
RPO	Yes			
Intelligent Slot	Yes			
Network Card	Optional, C-NMC			
Modbus Card	Optional, C-Modbus			
Dry Contactor Card	Optional, C-Relay			
Wireless Module	Optional, C-WIFI			
IOT Ethernet Port	RJ45			
Monitoring Software	Winpower, CertaUPS Monitor App			
PHYSICAL				
Dimension (WxDxH) mm	438 x 540 x 88 (2U)			
Net weight (Kg)	14	14	16	16
IP Protection Level	IP20			
ENVIRONMENT				
Operating Temperature	0-40°C (derating 50% above 40°C) excluding batteries			
Relative Humidity	0-95% (non-condensing)			
Operating Altitude	0-3000m (the load derating 1 % every up 100m @ 1000~3000m)			
Storage temperature (with battery)	-15°C - 40°C			
Storage temperature (without battery)	-25°C - 55°C			
Certification	CE, IEC/EN 62040, UKCA			

- (1) In CVCF mode, UPS needs to be de-rated to 60% capacity (rated output power and maximum charging current).
 (2) @ 220VAC input phase voltage, rated output power and maximum charging.

A FULL GLOSSARY OF TERMS CAN BE FOUND AT:
WWW.CERTAUPS.COM/SUPPORT/UPS-GLOSSARY/

FOR FURTHER INFORMATION OR ASSISTANCE, PLEASE CONTACT YOUR CertaUPS REPRESENTATIVE OR VISIT:
WWW.CERTAUPS.COM