

Ingenio SFC

Ingenio Static Frequency Converter

From 100 kVA – 2000 kVA

Borri range of Static Frequency Converters are designed and built for the harshest conditions and to provide high reliable power supply converting 50 Hz supply to 60 Hz equipment and to different voltages.

Using state-of-the-art IGBT technology with DSP (Digital Signal Processors) controls we convert the input AC power through a IGBT PFC sine-wave rectifier to DC and then to an AC sine-wave IGBT inverter to produce a full sine-wave output at the new frequency and voltage.



CONVERTER

Industrial Power

Applications

- Industry.
- Marine and Ports.
- Military.
- Transportation.
- Mining industries.

Main features

- Proven advanced IGBT technology.
- Compact design, high power density.
- No moving elements - low maintenance.
- High reliability and availability.
- Precise output frequency generation.
- Remote monitoring and control through Ethernet, Modbus TCP/IP protocols.
- Flexible in-built features.
- Optional operation with battery.
- Highly customizable.
- Easy maintenance and serviceability.

Ingenio SFC

Ingenio Static Frequency Converter

Ingenio SFC technical data

Utility - Input

Voltage	380 – 440 V \pm 10% 3P+N (or any voltage with input transformer)
Nominal supply frequency	50 or 60 Hz
Frequency tolerance	\pm 5 Hz
Harmonics	<3% THDi (at rated load)
Power Factor	Unity

Load - Output

Capacity rating	100 kVA to 2000 kVA pf 1
Voltage	380 – 480 V (or any voltage with output transformer)
Frequency	50 or 60 Hz (consult factory for other frequencies)
Voltage harmonics	<2.5% THDv (linear load)
Overload capability	120% for 10 mins; 150% for 30 seconds
Short circuit current limit	200% for 2 seconds
Voltage accuracy	50 or 60 Hz (consult factory for other frequencies)
Frequency accuracy	+/- 0.1%

Performance

Efficiency	95% Typically
------------	---------------

General

Enclosure IP rating	IP20 Cabinet (higher protection up to IP54 on request)
Operating temperature	0 - 40°C (up to 55°C with derating)
Cooling	Forced air
Capacity derating with elevation	-1.0 % / 100 m for application above 1000 m, 2000 m maximum
Humidity	< 95% non - condensing
Noise	< 65
Standard	Quality assurance, environment, health and safety: ISO 9001:2008, ISO 14001:2004, BS OHSAS 18001:2007; Safety: IEC/EN 62040-1; EMC: IEC/EN 62040-2; Environmental aspects: IEC/EN 62040-4; Test and performance: IEC/EN 62040-3; IEC62103 / EN 50178; CE Mark; Protection degree: IEC 60529 Marine classifications (on request): DV, DNV, GL, ABS, CCS (++) Marking: CE

Control interface

Digital inputs (voltage free contacts)	Start; Stop/Reset
Digital outputs (relay outputs)	Running (NO); Warning (NO); Fault (NC)
Relay output ratings	230 Vac 1 A

Standard features

- Internal input and output switches.
- 8 potential free contacts fault remote alarm.
- Power and control cable markings.
- Halogen free cable.
- Component markings.
- Bottom cable entry.
- Advanced Multi-functional LCD panel.

Ingenio SFC block diagram

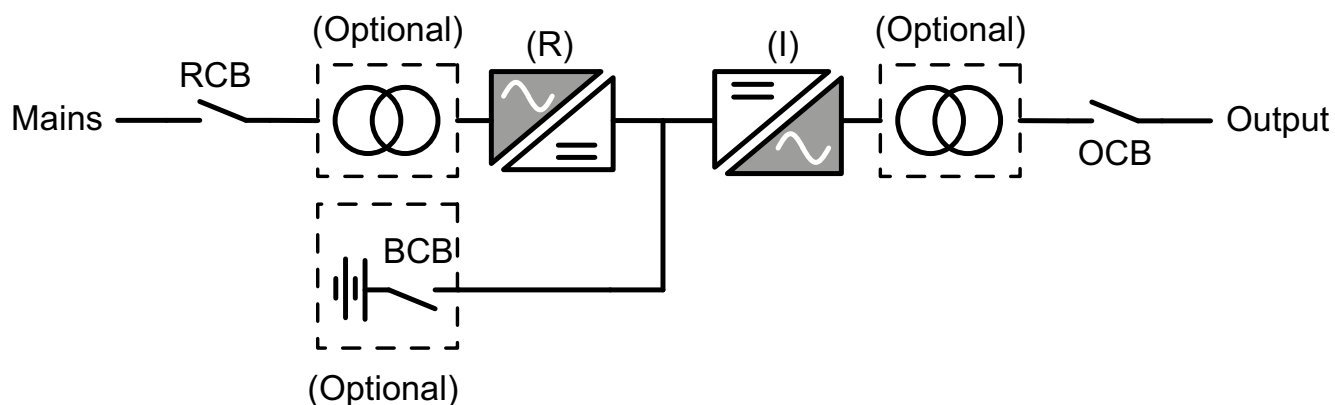

Options

Borri's engineer can help you to design the best solution for your application with a wide range of options, some of which are:

System

- Isolation Input and / or Output transformer.
- RS485 MODBUS communication port.
- Parallel redundant (CANBUS) with load sharing.
- Special mains input voltages up to 690 Vac and frequency 60 Hz.
- Tropicalized control electronics boards.
- Input CB or fuse or switch.
- Battery CB, fuse or switch in rectifier.
- AC distribution.
- Battery backup option.

Alarms and measurement

- Analog meters.
- Additional LED alarm indicators.
- Additional Relay cards 2 x 8 free contacts.
- Fan failure alarm.
- Earth fault alarm.

Control options

- Remote shutdown.
- Communication
 - TCP / IP interface
 - Protocol converters Profibus DP
 - J-bus DNP3
 - IEC 61850.

Mechanical

- Protection up to IP54.
- Vermin proof.
- Top cable entry.
- Cabinet heater.
- Special colour.
- Protection plates.
- Special cable marking (both ends).
- Air filters at air inlet.

Service

Customer's expectation defines Borri's priority from the early analysis of the project requirements to a worldwide commissioning and service.

Many thousands of systems have been successfully installed and maintained globally; with continuous support from a highly trained team of expert, certified technicians and engineers.

From the professional set-up of Borri's training center or on site, the training and service team provide support and tailored training at Borri or at your site. You can be assured of Borri support to the highest standards no matter where in the world you are.

- Planning, installation, commissioning
- Maintenance and Service
- Analytical testing
- Battery tests
- Spare parts
- Training



Who we are

Borri Group is a global provider of power electronics systems and solutions for harsh industrial and demanding commercial and ICT secure power requirements merging over eighty years of experience in developing, manufacturing and supplying uninterruptible power systems and solutions.

The Research and Development Team's expertise combines AC and DC power technologies spanning the worlds of both conventional and renewable energy, to provide innovative solutions for tomorrow's problems.

The company is comprised of three business units: Industrial Power, Critical Power and Renewable Power, headquartered in Bibbiena, Italy. Borri's latest products, based on Green Conversion operation, guarantee the best PUE for green data centres: proof of the ongoing company commitment to innovation.

Thanks to its highly skilled custom engineers Borri controls in-house the entire process: from feed studies to design, production and after-sales service guaranteeing state-of-the-art solutions.

Based in Italy with over 20,000 m² production area and a large high power test field, Borri can depend on its more than 90 years of experience and multi-disciplinary research and development to serve our customers best.

Since 1932, securing your power with passion and commitment.

